

## Validation Of Natural Frequencies Of Carbon Fiber Foot Plate Using FEA And Experimental Analysis

G. P. Shinde<sup>1</sup>, V. N Chougule<sup>2</sup>

<sup>1&2</sup>(Mechanical Engineering, MES College of Engineering, Pune, India)

**Abstract :** Footplates are mainly used by patients suffering from partial foot amputation. They assist a person suffering from lower extremities in walking by providing support for the foot and providing forward push off. Now a days foot plates are mainly available using carbon fiber material which is lightweight and has a very high strength to weight ratio. They have now become an alternative to plastic and metal orthoses. It also gives a better push off while coming back to its original position. During walking the loads acting on the footplate are dynamic in nature. During walking the footplate is subjected to repetitive loads that vary with respect to time which can cause failure of the plate and substantially reducing its useful life which is an important aspect of the product as carbon fiber is costly material. However if the natural frequency of the footplate is too far from the actual walking frequency, the problem can be considered static and stress analysis can be carried out to check the design adequacy of footplate under the loads acting in walking condition. The obtained stresses can be compared to the failure criteria of composites and the results will be compared to experimental results. In this study, the natural frequency of the footplate is calculated by modal analysis carried out in CAE software and compared with experimentally calculated results.

**Keywords -** Carbon-fiber, Composites, Foot plate, Modal Analysis

### I. INTRODUCTION

Orthoses are devices that are worn on the body to assist or limit motion, or reduce the load for a specific part of the body. These are designed very often to assist in treating a medical condition, such as deformities and abnormalities[1]. Orthoses or Foot plate, is designed to treat foot and ankle disorders in people with partial amputations[2]. These are designed in such a way that they provide a base or support that is stable and assists a person in the process of walking[7]. Partial foot amputation (PFA), deals with surgical removal of part of leg. It can be estimated that there are approximately 1.27 million Americans living with lower extremity amputation. More than 618,000 persons have a PFA making the incidence about 2 per 1000 head of population. Partial foot amputation is mostly caused by vascular insufficiency, diabetes, frostbite, trauma [4,5]. The different levels-of partial foot amputation are

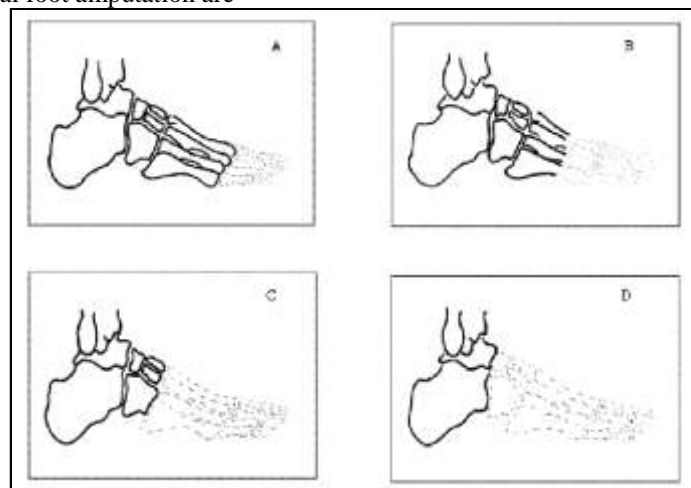

**Fig.1:** Schematic of various levels of partial foot amputation [5]

(A) Disarticulation of the metatarsophalangeal joint, (B) Transmetatarsal,  
(C) Tarsometatarsal (Lisfranc) (D) Transtarsal (Chopart)

The need for lightweight composite materials aroused in medical field because they are lightweight and have good strength and in case of footplate their flexibility gives better push off. They have now become an alternative to plastic and metal orthoses[6]. Carbon fiber is most widely used to make the footplates due to above mentioned benefits.–The objective of this study is to understand the loads acting on footplate during walking[3]. To carry out modal analysis of footplate to find the natural frequency of the plate and compare with the average human walking or stepping frequency[8]. This will help to arrive at a decision to carry static or

dynamic analysis of footplate. Foot plates are very useful for people with partial foot amputations. The foot plate can be placed inside the shoes as a sole.



Fig.2: Application of foot plate.

## II. METHODOLOGY

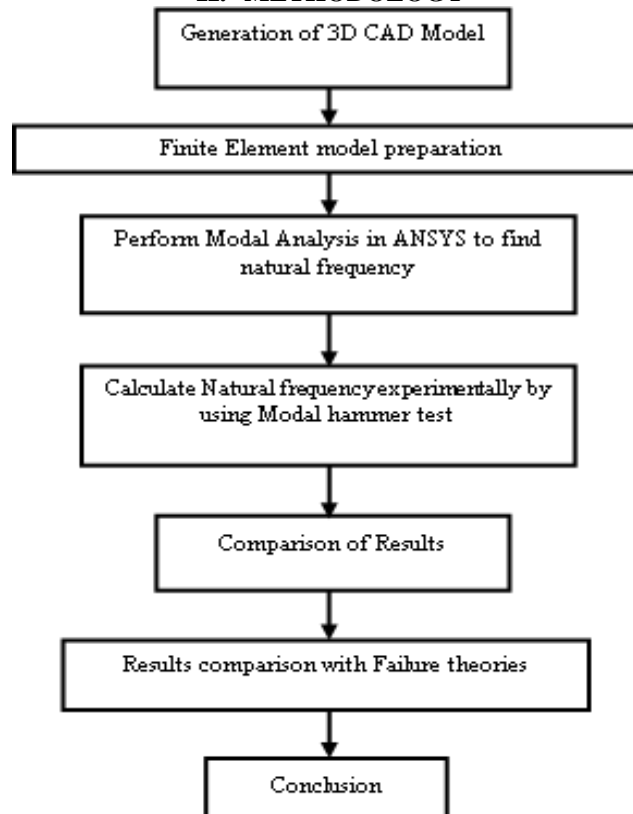

Fig.3: Block diagram of Methodology

## III. GENERATION OF 3D CAD MODEL OF FOOTPLATE

CAD model was created using CATIA V5 software with following dimensions and verified from Doctor specialized in the field of orthoses.

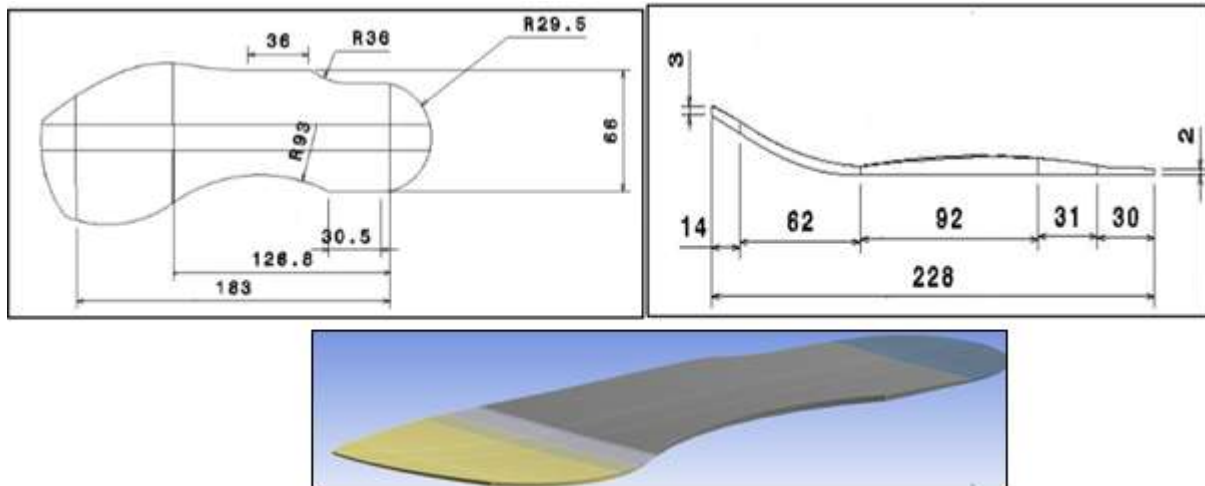

Fig.4: 3D CAD model of Footplate

#### IV. DEFINING MATERIALS PROPERTIES

Carbon fiber is the most widely used material for manufacturing footplates. Carbon fiber reinforced composite is extremely strong and light which contains fibers of carbon. It is expensive and difficult to manufacture but is commonly used in wide range of applications where high strength-to-weight ratio as well as rigidity is required. Carbon fiber composites are most widely used in aerospace and automotive industry, sports equipment and an increasing number of technical and commercial consumer applications. Epoxy is the binding polymer that is often used but other polymers like polyester are used in some cases.

Physical properties are high strength to weight ratio, rigidity, corrosion and fatigue resistance as well as good tensile strength. The material properties of carbon fiber are shown in Table 1.

Table 1: Material Properties

Properties of Material	Carbon Fiber	Units
Density	1.57	gm/cm <sup>3</sup>
Young's Modulus in (XY) Direction	61340	MPa
Young's Modulus in (YZ) Direction	61340	MPa
Young's Modulus in (XZ) Direction	6900	MPa
Tensile Strength in (X) Direction	805	MPa
Tensile Strength in (Y) Direction	805	MPa
Tensile Strength in (Z) Direction	50	MPa
Compressive Strength in (X) Direction	-509	MPa
Compressive Strength in (Y) Direction	-509	MPa
Compressive Strength in (Z) Direction	-170	MPa

#### V. FINITE ELEMENT MESHING AND BOUNDARY CONDITIONS

Meshing was done in ANSYS 17.2 Workbench module with quadrilateral brick elements as shown below Fig.5. As the study does not focus on stress analysis, shell layer meshing is not required. Actual part was manufactured by woven carbon fiber layers and hence material properties were used of woven carbon fiber from ANSYS material library. While walking, considering the toe-off condition of gait cycle, the toe region is fixed as shown below Fig.6 to simulate for toe-off condition.

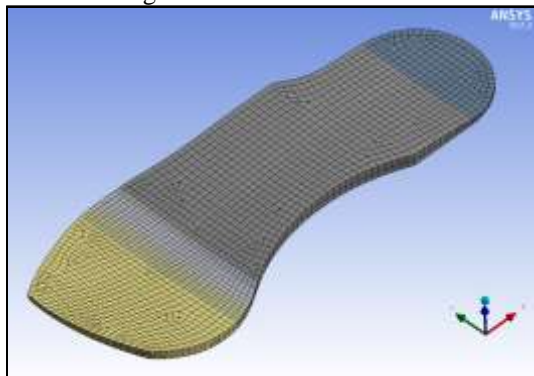

Fig.5: Meshed Model of Footplate

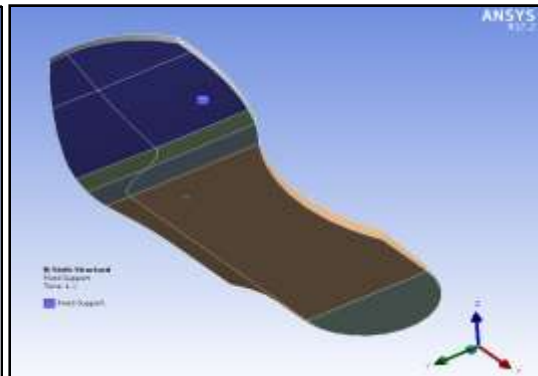
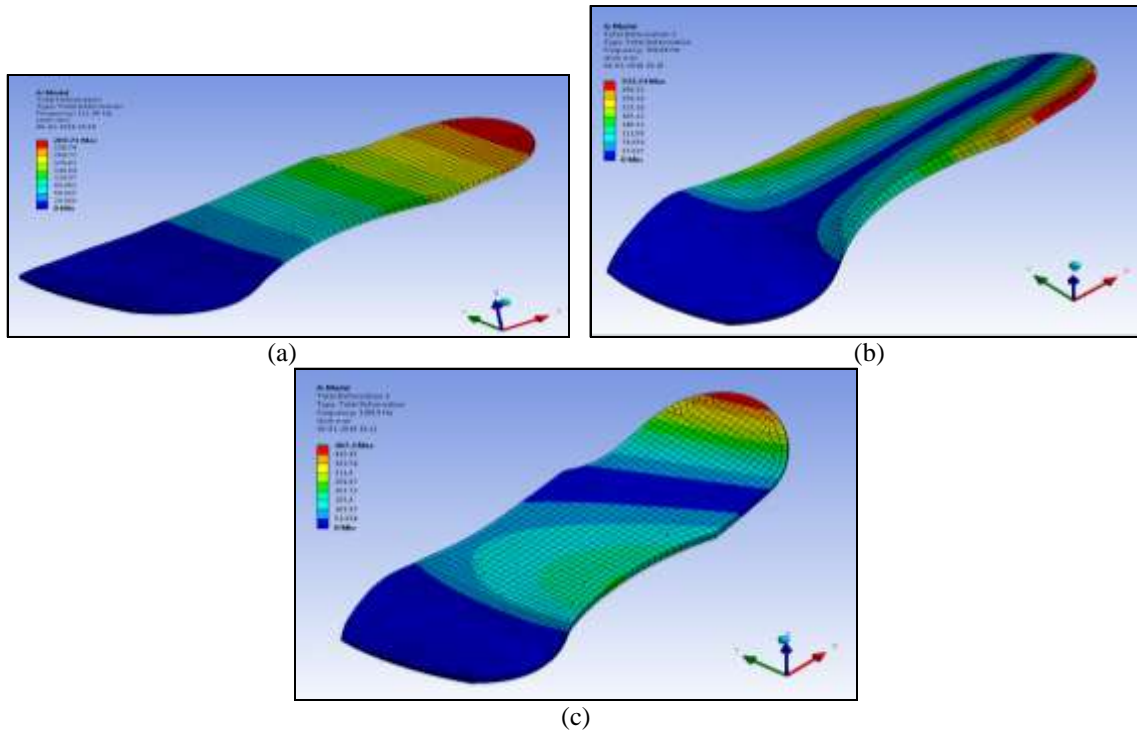

Fig.6: Fixity

### VI. MODAL ANALYSIS RESULTS



**Fig.7:** Modes Shape (a) Frequency 111.06 Hz, (b) Frequency 769 Hz, (c) Frequency 1168 Hz

The first three modes were extracted and the corresponding natural frequencies were obtained as shown below Table 2.

**Table 2:** First 3 Natural Frequencies

Modes	Frequency (Hz)
1	111.06
2	769.04
3	1168.8

### VII. EXPERIMENTAL VALIDATION

Modal analysis was carried out experimentally to validate ANSYS results. National Instruments Data acquisition (DAC) system was used to acquire data and data analysis was done in NI lab view software. The system consists of DAC (NI 9234 Module, 9171 Chassis), accelerometer which is attached to the footplate at heel end and a modal hammer to give excitation. The footplate is clamped on the table at the toe end and excitation is given at predefined points. The data acquired is processed in NI labview software and the corresponding values of natural frequencies are obtained. .

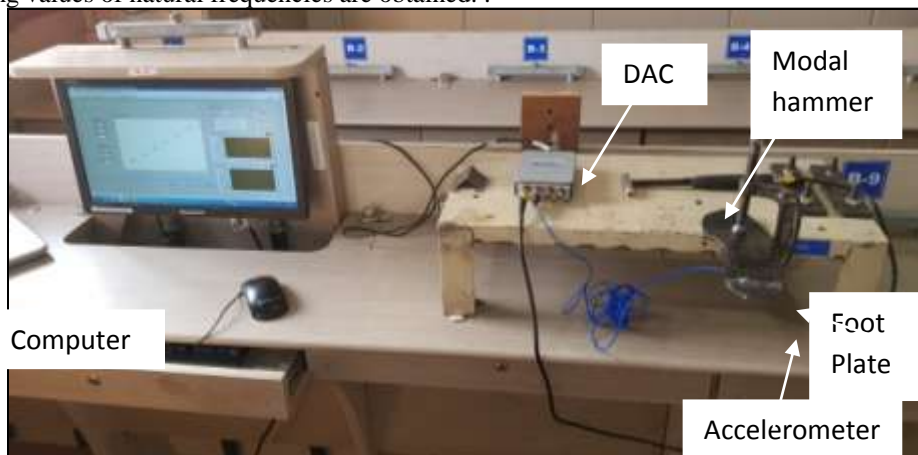

**Fig.8:** Experimental Setup for Modal Analysis

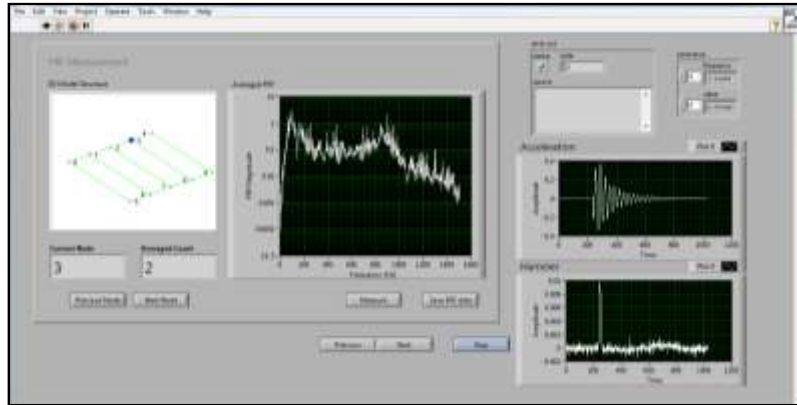

**Fig.9:** Experimental Setup Readings

### VIII. RESULTS

The results acquired from the experimental analysis were compared to the results from modal analysis in ANSYS and the natural frequencies are shown in below Table 3.

**Table 3:** Comparison of experimental and FEA results for natural frequency

Natural Frequency	ANSYS Results	Experimental Results
1	111.06 Hz	118.49 Hz
2	769.04 Hz	843.19 Hz
3	1168.8 Hz	1206.09 Hz

### IX. CONCLUSIONS

From the above results there is good co-relation between FEA and experimental results. Also the first natural frequency is more than 3 times the average human walking frequency of 2-3Hz. Hence the problem can be considered as static and further analysis and testing can be done. The further scope is to carry out finite element analysis of the foot plate and compare the stresses with failure theory of composites and to carry out experimental testing of footplate using actual load at particular frequency.

### REFERENCES

#### Journal Papers:

- [1]. Dennis J. Jannise, Erick J. Jannise. Foot ankle clin n Am, “Shoes, orthoses and prosthesis for partial foot amputation and diabetic foot infection” 15 (2010) pp. 509-523.
- [2]. Loading of the Knee Joint during Treadmill Walking – Measured in Four Patients Kutzner, I ; 1,2Heinlein, B; 1,3Bender, A; 1Rohlmann, A; 1Graichen, F; 1Bergmann, G+1Julius Wolff Institute, Charity - Universitätsmedizin Berlin, Germany.
- [3]. John H. Bowker, M.D. “ Partial foot and syme amputation: An overview clinical prosthetics and orthotics”, Digital Resource Foundation for Orthotics & Prosthetics, Vol.12 , 1987, pp.10-13.
- [4]. Yu-an Jin , Jeff plot , Roland chen , Jeffrey wenjman, Albert Shih , “Additive manufacturing of custom orthoses and prostheses- A Review”, Procedia CIRP, vol 36 (2015), pp. 199-204.
- [5]. A Parent, A Poulite Laforle, M, Laberg, R. Handy, R.Rochell and L. Ballaz, “Articulate Vs. Fixed carbon fiber prosthesis after transmetatarsal amputation- a case study”, Computer methods in Biomechanics and biomedical engineering, vol 17, 2014, pp.106-107.
- [6]. Aikaterini Pachi, Tianjian Ji , “Frequency and velocity of people walking” – The Structural Engineer, 2015 pp.36-40.
- [7]. BOOK:
- [8]. David A. Winter, Biomechanics and Motor Control of Human Movement,( Fourth Edition Copyright © 2009 John Wiley & Sons, Inc. ISBN: 978-0-470-39818-0.)
- [9]. THESES:
- [10]. Dillon M.P, Biomechanics models for analysis of partial foot amputee gaitl (PhD thesis): Queensland University of technology, Brisbrone (Australia), 2001.